



Engineering Standards

Name	BARCODE LABELING & DIRECT PART MARKING	Engineering Standard Number
Identifier	CORPORATE MANUFACTURING SPECIFICATION (FEATURE)	18287

Abstract

This specification defines minimum requirements for bar-coding individual components, assemblies and sub-assemblies for suppliers. The supplier shall strictly adhere to this specification, in addition to what is specified on part drawings.

Current Release Number 162021-101	Std. Revision Level 011		Page 1 of 23
--------------------------------------	----------------------------	--	--------------

CUMMINS CONFIDENTIAL

This document (and the information shown thereon) is **CONFIDENTIAL AND PROPRIETARY** and shall not be disclosed to others in hard copy or electronic form, reproduced by any means, or used for any purpose without written consent of Cummins Inc.



Engineering Standards

Name	BARCODE LABELING & DIRECT PART MARKING	Engineering Standard Number
Identifier	CORPORATE MANUFACTURING SPECIFICATION (FEATURE)	18287

Table of Contents

<u>Heading</u>	<u>Page Number</u>
Abstract	1
Table of Contents	2
1. Scope	3
2. Applicable Documents	3
3. Definitions	3
4. Data and Format	6
4.1. 2D Barcodes.....	6
4.2. 1D Barcode	9
4.3. Human Readable Information (HRI)	10
5. Location	10
5.1. Methods for Specifying Location of Barcode and HRI on the Drawing	10
5.2. Location and Size Dimensions	11
5.3. Location of CES 18111 Human Readable Information	11
Figure 1: Method One for a Label	12
Figure 2: Method One for a Direct Part Mark	13
Figure 3: Method Two for a Label.....	14
Figure 4: Method Two for a Direct Part Mark.....	15
Figure 5: Method One for a Direct Part Mark	16
Figure 6: Barcode Content Table Showing Serial Number or Lot Code,.....	17
Figure 7: Barcode Content Table Shows Unique Serial Number	18
6. Marking Methods	19
6.1. Marking Methods Consideration	19
7. Quality Control Requirements.....	21
7.1. Customer Approval.....	21
7.2. Suppliers' In-process Verification	21
7.3. Label Functional Requirements: Substrates	22
7.4. Conditions for Corrective Action on Suppliers	23
8. Packaging Requirements and Labels for Packaging	23
9. Reference Readings	23

Current Release Number 162021-101	Std. Revision Level 011		Page 2 of 23
--------------------------------------	----------------------------	--	--------------

CUMMINS CONFIDENTIAL

This document (and the information shown thereon) is CONFIDENTIAL AND PROPRIETARY and shall not be disclosed to others in hard copy or electronic form, reproduced by any means, or used for any purpose without written consent of Cummins Inc.



Engineering Standards

Name	BARCODE LABELING & DIRECT PART MARKING	Engineering Standard Number
Identifier	CORPORATE MANUFACTURING SPECIFICATION (FEATURE)	18287

1. Scope

This specification defines minimum requirements for bar-coding individual components, assemblies and sub-assemblies and does not change or negate any part(s) of CES 18111. The supplier shall strictly adhere to this specification, in addition to what is specified on the part drawings.

2. Applicable Documents

Applicable documents listed below may be obtained from the respective organizations listed in CES 10054, Standards Organizations Addresses.

- a. AIAG B-4, Parts Identification and Tracking Application Standard
- b. AIAG B-8, Quality Assurance Guide for Shipping Labels
- c. AIAG B-17, 2D Direct Parts Marking Guideline
- d. AIM DPM-1-2006, Direct Part Mark (DPM) Quality Guideline
- e. ANSI INCITS 182, Information Systems-Bar Code Print Quality-Guideline
- f. ASME Y14.43, Dimensioning and Tolerancing Principles for Gages and Fixtures
- g. CES 10006, Codes, Supplier Identification
- h. CES 10054, Standards Organizations Addresses
- i. CES 10056, Glossary
- j. CES 18111, Identification, Prod Item
- k. CES 19041, Global Packaging Std Production Parts
- l. ISO 15415, Information Technology-Automatic Identification and Data Capture Techniques-Barcode Symbol Print Quality Test Specification-Two-dimensional Symbols
- m. ISO 16022, Information Technology Automatic Identification and Data Capture Techniques Data Matrix Barcode Symbology Specification
- n. MHI MH10.8.2, Data Identifier & Application Identifier Standard

3. Definitions

Terms used in this standard that have a general definition for usage in Cummins Engineering Standards are defined in CES 10056, Glossary. The definitions below are provided to clarify the terminology used in this standard. A more detailed list and explanation of definitions is provided in AIAG B-4.

Current Release Number 162021-101	Std. Revision Level 011		Page 3 of 23
--------------------------------------	----------------------------	--	--------------

CUMMINS CONFIDENTIAL

This document (and the information shown thereon) is CONFIDENTIAL AND PROPRIETARY and shall not be disclosed to others in hard copy or electronic form, reproduced by any means, or used for any purpose without written consent of Cummins Inc.



Name	BARCODE LABELING & DIRECT PART MARKING	Engineering Standard Number
Identifier	CORPORATE MANUFACTURING SPECIFICATION (FEATURE)	18287

3.1. 1D Barcode

1D Barcode is linear or one-dimensional type symbol most commonly used on most consumer products. Depending on the specific type, data is encoded as a function of the width of the dark lines and the space between them. Hence, they are also called linear barcodes. Common types include Code 39 and Code 128.

3.2. 2D Barcode

2D Barcode is a two dimensional type symbol that contains data as a function of the specific arrangement of dark and light squares. The codes contain data in two directions, along the X and Y axis. Common symbologies include Data Matrix, PDF 417 and QR code.

3.3. Check Digits

Check Digits is an error checking method used in 1D barcodes.

3.4. Data Field

Data Field is the actual data that is encoded as opposed to format characters like the data identifier. For example, in the string 1P1234567; 1P is the data identifier (format character) while 1234567 is the data field. 1P stands for Item identification code assigned by the supplier which is 1234567.

3.5. Data Identifier (DI)

A data identifier is an upper case alphabet or a combination of an alphabet and a number. It is a prefix to the data and defines what the data that follows it stands for. For example: P1234567 would mean 1234567 is a customer assigned part number, where P-the data identifier-stands for customer assigned part number.

3.6. Data Separator (also known as Delimiters)

Data Separator is a character used to separate data fields to facilitate decoding.

3.7. Direct Part Mark

Direct part mark is a barcode symbol marking that is directly applied onto the part surface (dot peening, laser marking, etc.)

Current Release Number 162021-101	Std. Revision Level 011		Page 4 of 23
--------------------------------------	----------------------------	--	--------------

CUMMINS CONFIDENTIAL

This document (and the information shown thereon) is CONFIDENTIAL AND PROPRIETARY and shall not be disclosed to others in hard copy or electronic form, reproduced by any means, or used for any purpose without written consent of Cummins Inc.



Name	BARCODE LABELING & DIRECT PART MARKING	Engineering Standard Number 18287
Identifier	CORPORATE MANUFACTURING SPECIFICATION (FEATURE)	

3.8. Error Checking and Correcting 200 (ECC 200)

Error Checking and Correcting 200 is an algorithm defined in ISO 16022 that builds in redundancies in the 2D Data Matrix barcode so that reading is possible even after suffering about 40% of damage.

3.9. Intrusive Marking Methods

Intrusive marking methods alter a part’s surface (abrade, cut, burn, vaporize, etc.) and can affect surface strength or generate stress risers. These methods should be considered “controlled defects” and may degrade material properties beyond acceptable limits. Metallurgical testing may be required for some intrusive markings, especially on thin stampings (e.g. oil pans).

3.10. Module (also known as Cell or Element)

Module is a single cell in a Data Matrix used to encode one bit of data.

3.11. Non-intrusive Marking Methods

Non-intrusive marking methods generally do not affect surface strength or generate stress risers. These methods add marking material (labels, ink jet, laser bonding), leave raised material (cast/forge/mold), or leave depressions (cast/forge/mold).

3.12. Quiet Zone

Quiet Zone is the empty region of space required around 1D or 2D barcodes as defined in international standards. For 2D barcodes, quiet zones are required all around the symbol whereas for 1D barcodes, quiet zones are required at the leading and trailing ends.

3.13. Reading (also known as Decoding)

Reading is defined as extracting the data from the symbol. The reading process differs from verification process as defined in Section [3.16. Verification on page 6](#).

3.14. Symbol Dimension

Symbol Dimension is the overall physical length and width dimensions of the 2D barcode usually specified in millimeters.

Current Release Number 162021-101	Std. Revision Level 011		Page 5 of 23
--------------------------------------	----------------------------	--	--------------

CUMMINS CONFIDENTIAL

This document (and the information shown thereon) is CONFIDENTIAL AND PROPRIETARY and shall not be disclosed to others in hard copy or electronic form, reproduced by any means, or used for any purpose without written consent of Cummins Inc.



Name	BARCODE LABELING & DIRECT PART MARKING	Engineering Standard Number 18287
Identifier	CORPORATE MANUFACTURING SPECIFICATION (FEATURE)	

3.15. Symbol Size

Symbol Size is the number of rows and columns in a Data Matrix.

3.16. Verification

Verification is the quality grading of a barcode (1D or 2D) on any medium (label or direct mark on parts) per defined quality metrics. Quality metrics are defined in industry verification standards. Typically, quality metrics are graded on a Pass/Fail basis and/or a graded basis. Graded basis implies that certain quality metrics are measured and scored typically between A to F depending on the verification standard used. Verification of barcode quality is not the same as scanning and being able to read the barcode.

3.17. X-Dimension

X-Dimension is the dimension of the most basic square element (dark or light module) in a 2D barcode usually specified in mils; where 1 mil = 1/1000 inch.

4. Data and Format

4.1. 2D Barcodes

4.1.1. Data Matrix is the only Cummins approved symbology for 2D barcode. Some of the data commonly contained in a 2D barcode are as follows, along with their data identifiers:

- a. Cummins part number (Prefixed by data identifier “P”, designating the part code or number as determined and specified on the Cummins drawing, at the ID-level at which the part is purchased)
- b. Supplier serial number for component traceability to raw material (Prefixed by data identifier “S”, designating the unique supplier-assigned serial number) (Refer to Section [4.1.2.2. on page 7](#) if serial number not unique by itself.)
- c. Supplier lot code, for component traceability to raw material (Prefixed by data identifier “1T”, designating supplier assigned traceability information, such as batch code, lot code, shift number, date code correlating back to raw material.)
- d. Cummins assigned supplier identification, per CES 10006 if CES 18308 is applicable, supplier or product identification may be used per CES 18308. (Prefixed by data identifier “V”)
- e. Date code in the format of YYDDD (Prefixed by data identifier “D”, designating supplier assigned date code that does not provide traceability all the way back to raw material.)
- f. Mutually defined between customer/supplier such as Trim Codes, Part Pairing, etc. (Prefixed by data identifier “Z”)
- g. Other component specific data (refer to MHI MH10.8.2)

Current Release Number 162021-101	Std. Revision Level 011		Page 6 of 23
--------------------------------------	----------------------------	--	--------------

CUMMINS CONFIDENTIAL

This document (and the information shown thereon) is CONFIDENTIAL AND PROPRIETARY and shall not be disclosed to others in hard copy or electronic form, reproduced by any means, or used for any purpose without written consent of Cummins Inc.



Engineering Standards

Name	BARCODE LABELING & DIRECT PART MARKING	Engineering Standard Number
Identifier	CORPORATE MANUFACTURING SPECIFICATION (FEATURE)	18287

4.1.2. Not all parts require traceability. Where traceability is specified, enough of the above fields shall be present in the Data Matrix or barcode to provide full supplier traceability through their manufacturing process. The minimum fields required in the Data Matrix shall be specified on the engineering drawing. Supplier shall adhere to drawing requirements. In every case, data shall be separated by semicolon as a data separator. There is no fixed length for each data field. The data is bounded by the data identifier at the beginning and data separator, or end of string, at the end. No padded characters (blank spaces) or non-printables allowed in 2D code dataset. No semicolons used except as separators. If character limits exist in any fields, per customer requirements, these limits shall be specified on the print in a note.

4.1.2.1. The information required for traceability and the format of the serial or lot code may vary from one supplier to another. Using their internal systems, the supplier shall be able to trace product defect issues given the tracking number. The supplier should exercise good judgment in determining the most important information to capture in a serial number or lot code for component traceability. The Tier 1 supplier is expected to have traceability back to raw material. Supplier shall work with Cummins Supplier Quality Engineering. Cummins Supplier Quality Engineer shall document specific format of the 2D Data Matrix, character by character, in the Production Part Approval Process (PPAP) documentation.

4.1.2.2. Where component traceability to raw material is required, the drawing shall specify the requirement of serial number or lot code. If either serial number or lot code are permissible, the drawing shall indicate the allowed substitution. The unique serial number may consist of various manufacturing data to make it unique.

4.1.2.2.1. Examples of types of information that may be included in a serial number to make it unique:

- a. YYDDD - Production Date in Julian format, if applicable.
- b. HH - Heat Code, if applicable.
- c. LL - Machining Line, if applicable.
- d. ##### - Sequential number of part produced.

4.1.2.2.2. Information to be included in serial number at the discretion of the supplier as long as adequate traceability is required and field is unique. Examples of resulting unique serial number:

- a. Production Date in Julian format + Sequential number of part produced.
 - SYYDDD#####
- b. Heat Code + Machining Line + Production Date in Julian Format + Sequential number of part produced.
 - SHHLLYYDDD#####

Current Release Number 162021-101	Std. Revision Level 011		Page 7 of 23
--------------------------------------	----------------------------	--	--------------

CUMMINS CONFIDENTIAL

This document (and the information shown thereon) is **CONFIDENTIAL AND PROPRIETARY** and shall not be disclosed to others in hard copy or electronic form, reproduced by any means, or used for any purpose without written consent of Cummins Inc.



Engineering Standards

Name	BARCODE LABELING & DIRECT PART MARKING	Engineering Standard Number
Identifier	CORPORATE MANUFACTURING SPECIFICATION (FEATURE)	18287

4.1.2.2.3. Examples of types of information that may be included in a lot code:

- a. YYDDD - Production Date in Julian format, if applicable.
- b. HH - Heat Code, if applicable.
- c. LL - Machining Line, if applicable.

4.1.2.2.4. Information to be included in lot code at the discretion of the supplier, as long as adequate traceability is provided. Examples of lot code format:

- a. Date of Production in Julian format - 1TYDDDD
- b. Heat Code + Machining Line + Date of Production in Julian format - 1THLLLYDDDD

4.1.2.2.5. The detailed breakdown for serial number or lot code format should not be listed on the print; but should be recorded in the PPAP documentation and shall be shared with the Product Engineer or Designer, upon request.

4.1.2.3. Refer to [Figure 5: Method One for a Direct Part Mark on page 16](#) to see an example of how the required contents of a 2D Barcode and human readable information will be displayed on a drawing. A Barcode Content Table will not typically contain all of the fields shown in [Figure 5: Method One for a Direct Part Mark on page 16](#). However, each Barcode Content Table will include text at the bottom to confirm the type of traceability required.

4.1.2.4. If the drawing shows the phrase, “Provide unique serial number or lot code. Do not provide both.” at the bottom of the Barcode Content Table, as in [Figure 6: Barcode Content Table Showing Serial Number or Lot Code, on page 17](#), it means component traceability is required as either a lot code or serial number. Do not provide both lot code and serial number.

4.1.2.5. If the drawing shows the phrase, “Provide unique serial number.” at the bottom of the Barcode Content Table, as in [Figure 7: Barcode Content Table Shows Unique Serial Number on page 18](#), it means a unique serial number is required for component traceability.

4.1.2.6. If the drawing shows the phrase, “No Component Traceability” at the bottom of the Barcode Content Table, as in [Figure 1: Method One for a Label on page 12](#) through [Figure 4: Method Two for a Direct Part Mark on page 15](#), it means lot code and serial number are not needed for component traceability. All other listed contents in the Barcode Content Table are needed for the 2D Barcode and HRI.

Current Release Number 162021-101	Std. Revision Level 011		Page 8 of 23
--------------------------------------	----------------------------	--	--------------

CUMMINS CONFIDENTIAL

This document (and the information shown thereon) is **CONFIDENTIAL AND PROPRIETARY** and shall not be disclosed to others in hard copy or electronic form, reproduced by any means, or used for any purpose without written consent of Cummins Inc.



Engineering Standards

Name	BARCODE LABELING & DIRECT PART MARKING	Engineering Standard Number 18287
Identifier	CORPORATE MANUFACTURING SPECIFICATION (FEATURE)	

4.1.3. If more than one set of data is present in the barcode, the order of the data shall be that the part number be the first in the string, followed by serial number or lot code. Other component specific data shall be placed after those data fields.

4.1.3.1. Barcode Format Examples:

- a. P1234567;S987654321;VABCDE (all in one barcode)
- b. P1234567;1T123456 (all in one barcode)
- c. P1234567 (all in one barcode)

4.1.3.2. For approved data identifier, please refer to MHI MH10.8.2 Data Application Identifier Standard.

4.1.4. Data Matrix barcodes should have an X Dimension of 0.25 mm-0.88 mm (10-35 mils). The actual X Dimension should be decided upon after due testing of surface finish and readability of the mark. Guidelines for determining a suitable X Dimension for a given surface finish are provided in AIAG B-17. The symbol dimensions shall meet the requirements specified in AIAG B-4, table titled “2D Symbol Size Classifications by Element and Symbol Dimensions”. The preferred 2D symbol size (dimensionally) is C or D on a flat surface as defined in AIAG B-4. Data Matrix codes located on round/curved surfaces shall not have the symbol dimension exceed 16% of the component diameter. Rectangular dimension codes may be used for such applications with limited space.

4.1.5. Data Matrix 2D barcodes shall include a quiet zone consisting of a minimum of one X- dimension and shall incorporate at least ECC-200 error-correction data.

4.2. 1D Barcode

4.2.1. Code 39 is the only Cummins approved symbology for 1D barcode. Its data format shall meet the requirements as specified in AIAG B-4. Fields should consist of a data identifier, immediately followed by its associated data. Only one data field is allowed per symbol.

4.2.2. For approved data identifier, please refer to MHI MH10.8.2 Data Application Identifier Standard.

4.2.2.1. Barcode Format Examples:

- a. Cummins part number only P1234567
- b. Supplier serial number only S123456789
- c. Supplier lot code only 1T123456789

Current Release Number 162021-101	Std. Revision Level 011		Page 9 of 23
--------------------------------------	----------------------------	--	--------------

CUMMINS CONFIDENTIAL

This document (and the information shown thereon) is CONFIDENTIAL AND PROPRIETARY and shall not be disclosed to others in hard copy or electronic form, reproduced by any means, or used for any purpose without written consent of Cummins Inc.



Name	BARCODE LABELING & DIRECT PART MARKING	Engineering Standard Number
Identifier	CORPORATE MANUFACTURING SPECIFICATION (FEATURE)	18287

4.2.3. Code 39 barcode densities and dimensions shall meet the requirements as specified in AIAG B-4 under the corresponding section.

4.2.4. Code 39 barcode quiet zones shall meet the requirements as specified in AIAG B-4, under the corresponding section. Check digits shall not be added in Code 39 barcodes. No extra or special characters shall be added in 1D Barcode content.

4.3. Human Readable Information (HRI)

In this standard, HRI refers to only the human readable information that is associated with the barcode.

4.3.1. The human readable information (HRI) shall appear as specified in the engineering drawing. The HRI shall not include the coded start or stop characters, but shall represent the encoded information. Cummins' preference is to receive HRI with data identifiers in parenthesis per AIAG B-4, as shown in Section 4.3.1.1. [HRI Format Examples: on page 10.](#)

4.3.1.1. HRI Format Examples:

- a. (P)1234567
- b. (S)123456789

4.3.2. HRI minimum character height should be 2.0 mm [0.079 in], unless otherwise specified on the print.

5. Location

The engineering drawing will specify the barcode location and its dimensions and orientation of the barcode, the method of marking (e.g.: laser or dot-peen), the type of barcode (e.g.: 1D or 2D), the location of the human readable information and the medium (e.g.: label or direct part mark), if required.

5.1. Methods for Specifying Location of Barcode and HRI on the Drawing

5.1.1. Method One for Specifying Location of Barcode and HRI on a Drawing

Both barcode symbol and HRI text are to be located in a common rectangular boundary (region). The barcode and HRI shall be located within the specified boundary without concern for their relevance to each other as long as they do not overlap or interfere with legibility or use of an electronic reader. See [Figure 1: Method One for a Label on page 12](#) and [Figure 2: Method One for a Direct Part Mark on page 13.](#)

Current Release Number 162021-101	Std. Revision Level 011		Page 10 of 23
--------------------------------------	----------------------------	--	---------------

CUMMINS CONFIDENTIAL

This document (and the information shown thereon) is CONFIDENTIAL AND PROPRIETARY and shall not be disclosed to others in hard copy or electronic form, reproduced by any means, or used for any purpose without written consent of Cummins Inc.



Engineering Standards

Name	BARCODE LABELING & DIRECT PART MARKING	Engineering Standard Number
Identifier	CORPORATE MANUFACTURING SPECIFICATION (FEATURE)	18287

5.1.2. Method Two for Specifying Location of Barcode and HRI on the Drawing

Both barcode symbol and HRI text are to be located within the specified boundary (region), however, the barcode symbol shall be placed in a specific smaller dimensioned boundary within the larger boundary. The HRI may be totally or partially inside the smaller boundary as long as it does not overlap the barcode or interfere with legibility or use of an electronic reader. See [Figure 3: Method Two for a Label on page 14](#) and [Figure 4: Method Two for a Direct Part Mark on page 15](#).

5.2. Location and Size Dimensions

The boundary size and location are specified with basic dimensions similar to dimensions that define datum target areas. Gaging tolerances per ASME Y14.43 apply.

5.3. Location of CES 18111 Human Readable Information

In addition, human readable information related to CES 18111 may be located inside the boundary with the barcode HRI if space permits and legibility requirements are satisfied.

Current Release Number 162021-101	Std. Revision Level 011		Page 11 of 23
--------------------------------------	----------------------------	--	---------------

CUMMINS CONFIDENTIAL

This document (and the information shown thereon) is **CONFIDENTIAL AND PROPRIETARY** and shall not be disclosed to others in hard copy or electronic form, reproduced by any means, or used for any purpose without written consent of Cummins Inc.



Name	BARCODE LABELING & DIRECT PART MARKING	Engineering Standard Number
Identifier	CORPORATE MANUFACTURING SPECIFICATION (FEATURE)	18287

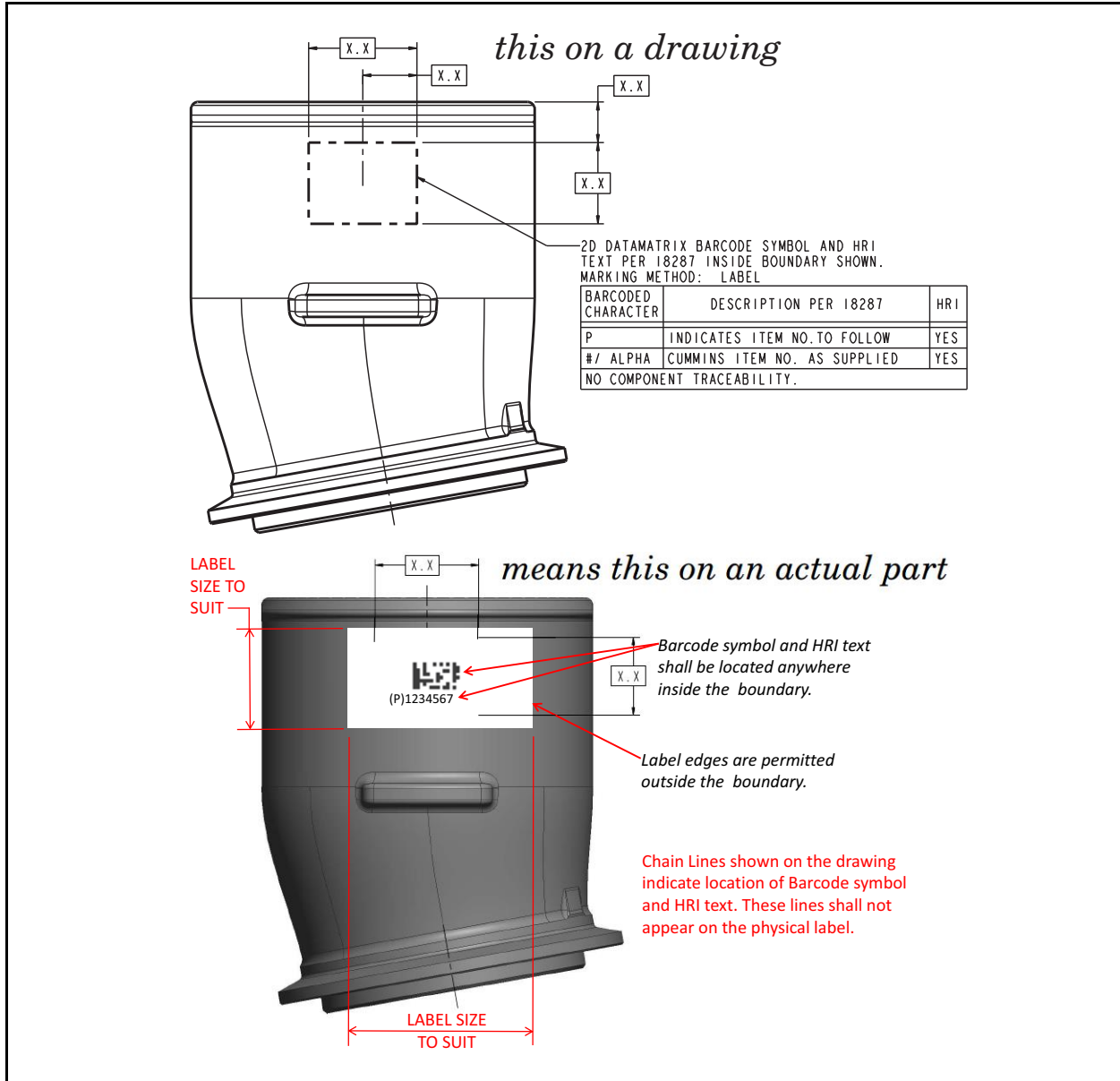

Figure 1: Method One for a Label with NO Component Traceability Required

Current Release Number 162021-101	Std. Revision Level 011		Page 12 of 23
--------------------------------------	----------------------------	--	---------------

CUMMINS CONFIDENTIAL

This document (and the information shown thereon) is CONFIDENTIAL AND PROPRIETARY and shall not be disclosed to others in hard copy or electronic form, reproduced by any means, or used for any purpose without written consent of Cummins Inc.



Name	BARCODE LABELING & DIRECT PART MARKING	Engineering Standard Number
Identifier	CORPORATE MANUFACTURING SPECIFICATION (FEATURE)	18287

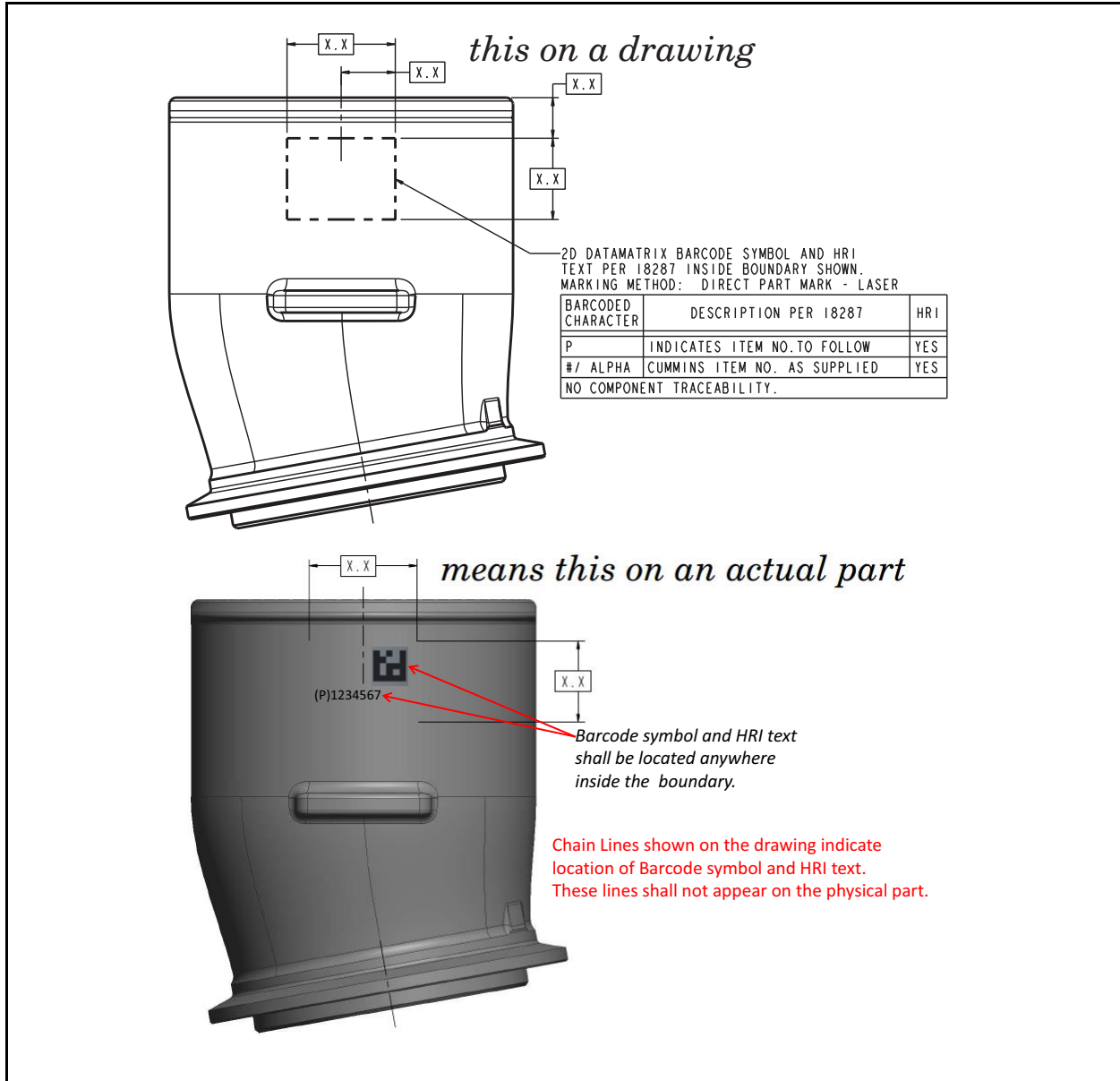

Figure 2: Method One for a Direct Part Mark with NO Component Traceability Required

Current Release Number 162021-101	Std. Revision Level 011	Page 13 of 23
--------------------------------------	----------------------------	---------------

CUMMINS CONFIDENTIAL

This document (and the information shown thereon) is CONFIDENTIAL AND PROPRIETARY and shall not be disclosed to others in hard copy or electronic form, reproduced by any means, or used for any purpose without written consent of Cummins Inc.



Name	BARCODE LABELING & DIRECT PART MARKING	Engineering Standard Number
Identifier	CORPORATE MANUFACTURING SPECIFICATION (FEATURE)	18287

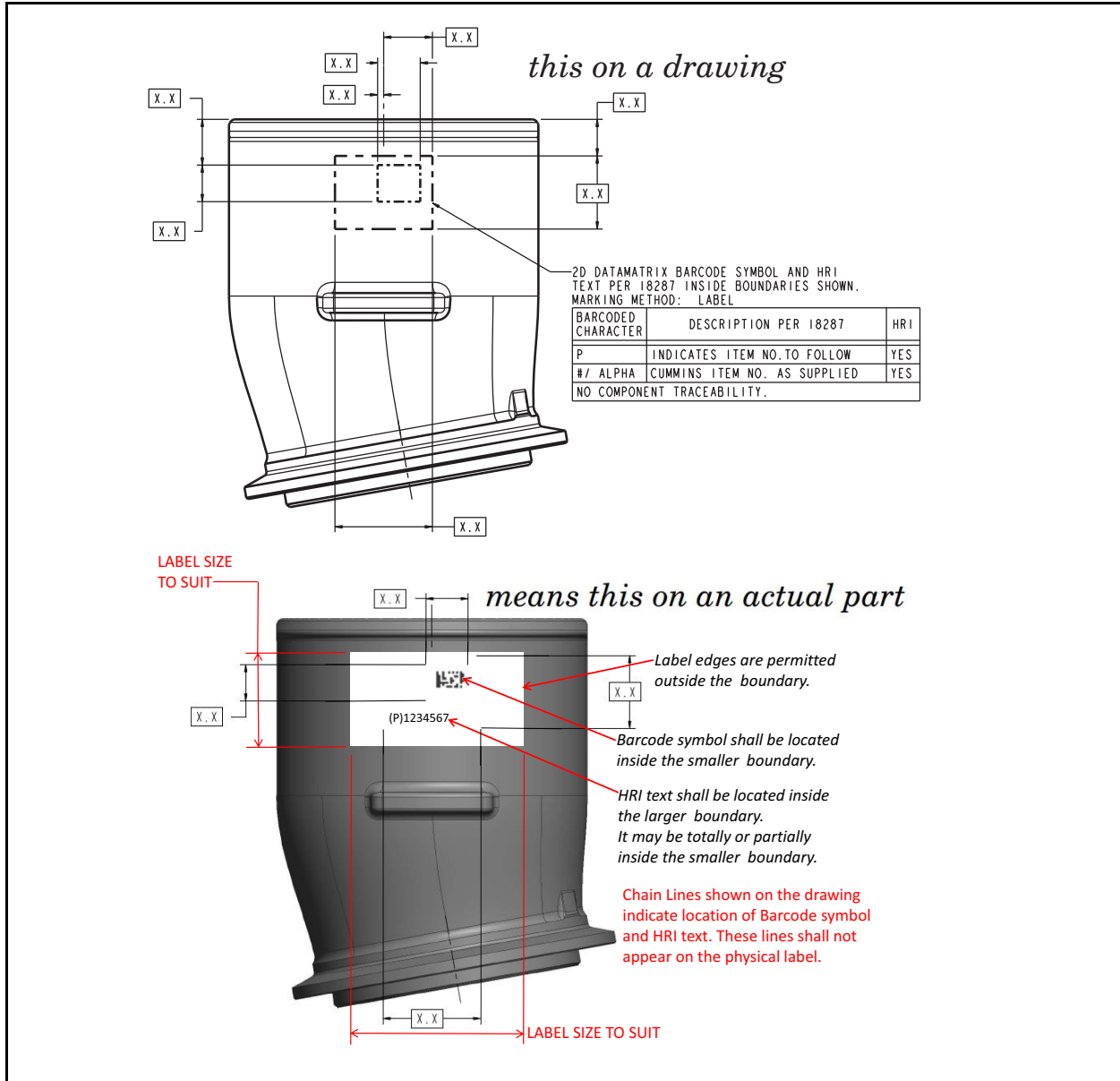

Figure 3: Method Two for a Label with NO Component Traceability Required

Current Release Number 162021-101	Std. Revision Level 011	Page 14 of 23
--------------------------------------	----------------------------	---------------

CUMMINS CONFIDENTIAL

This document (and the information shown thereon) is CONFIDENTIAL AND PROPRIETARY and shall not be disclosed to others in hard copy or electronic form, reproduced by any means, or used for any purpose without written consent of Cummins Inc.



Name	BARCODE LABELING & DIRECT PART MARKING	Engineering Standard Number
Identifier	CORPORATE MANUFACTURING SPECIFICATION (FEATURE)	18287

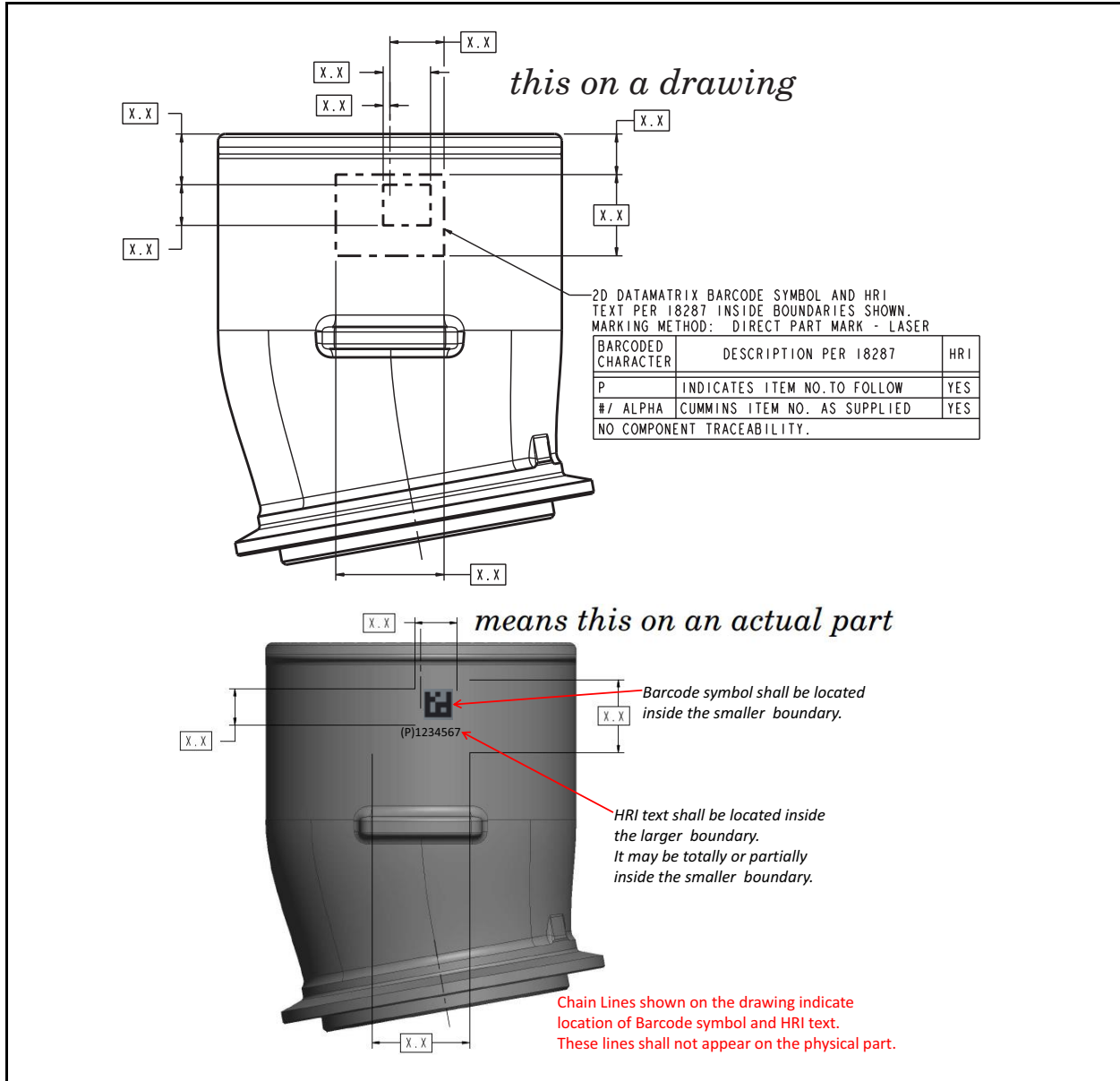

Figure 4: Method Two for a Direct Part Mark with NO Component Traceability Required

Current Release Number 162021-101	Std. Revision Level 011	Page 15 of 23
--------------------------------------	----------------------------	---------------

CUMMINS CONFIDENTIAL

This document (and the information shown thereon) is CONFIDENTIAL AND PROPRIETARY and shall not be disclosed to others in hard copy or electronic form, reproduced by any means, or used for any purpose without written consent of Cummins Inc.



Name	BARCODE LABELING & DIRECT PART MARKING	Engineering Standard Number
Identifier	CORPORATE MANUFACTURING SPECIFICATION (FEATURE)	18287

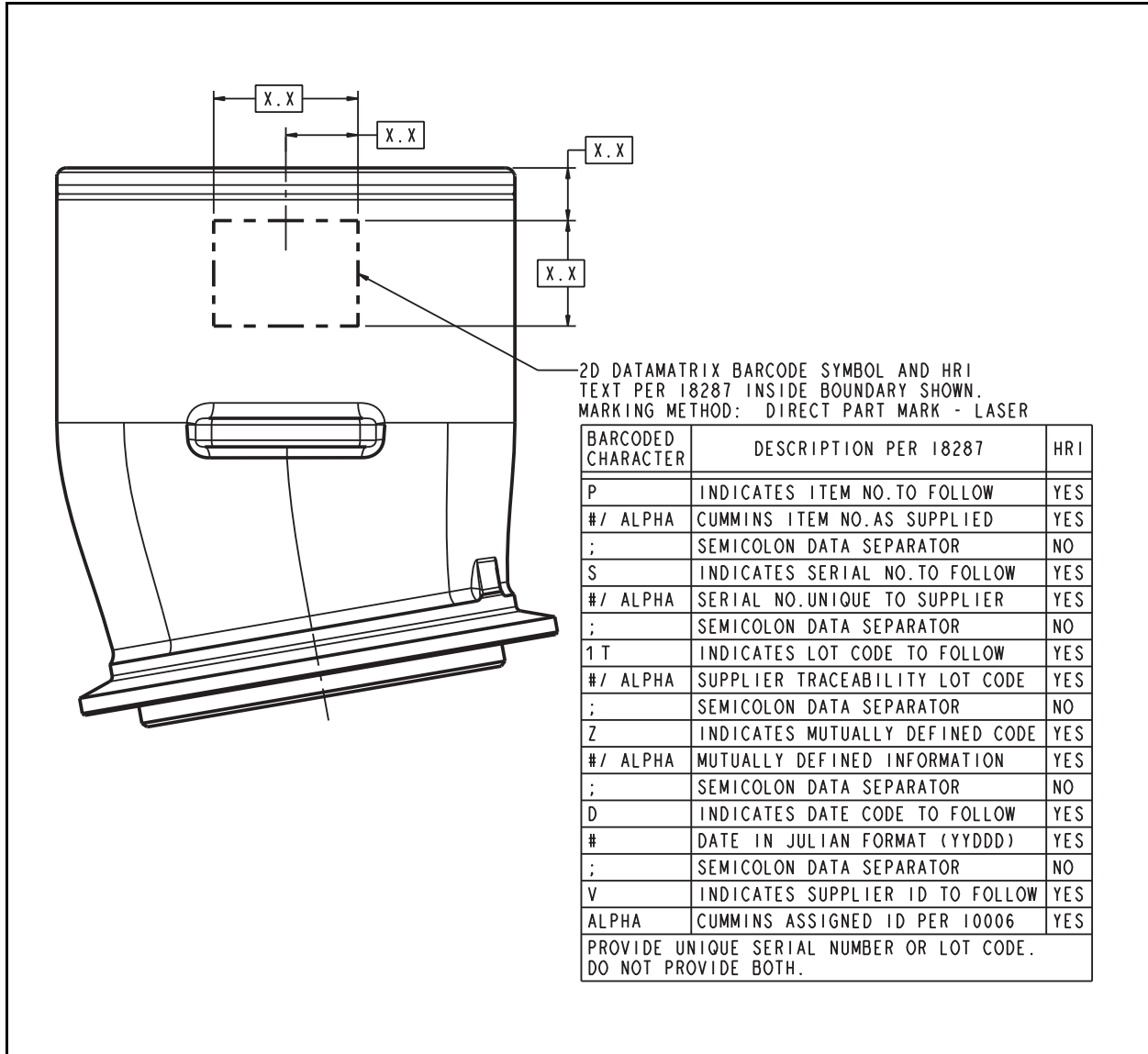

Figure 5: Method One for a Direct Part Mark with Component Traceability Required as Unique Serial Number or Lot Code and Other Required Information in 2D Data Matrix

Current Release Number 162021-101	Std. Revision Level 011	Page 16 of 23
--------------------------------------	----------------------------	---------------

CUMMINS CONFIDENTIAL

This document (and the information shown thereon) is **CONFIDENTIAL AND PROPRIETARY** and shall not be disclosed to others in hard copy or electronic form, reproduced by any means, or used for any purpose without written consent of Cummins Inc.



Name	BARCODE LABELING & DIRECT PART MARKING	Engineering Standard Number
Identifier	CORPORATE MANUFACTURING SPECIFICATION (FEATURE)	18287

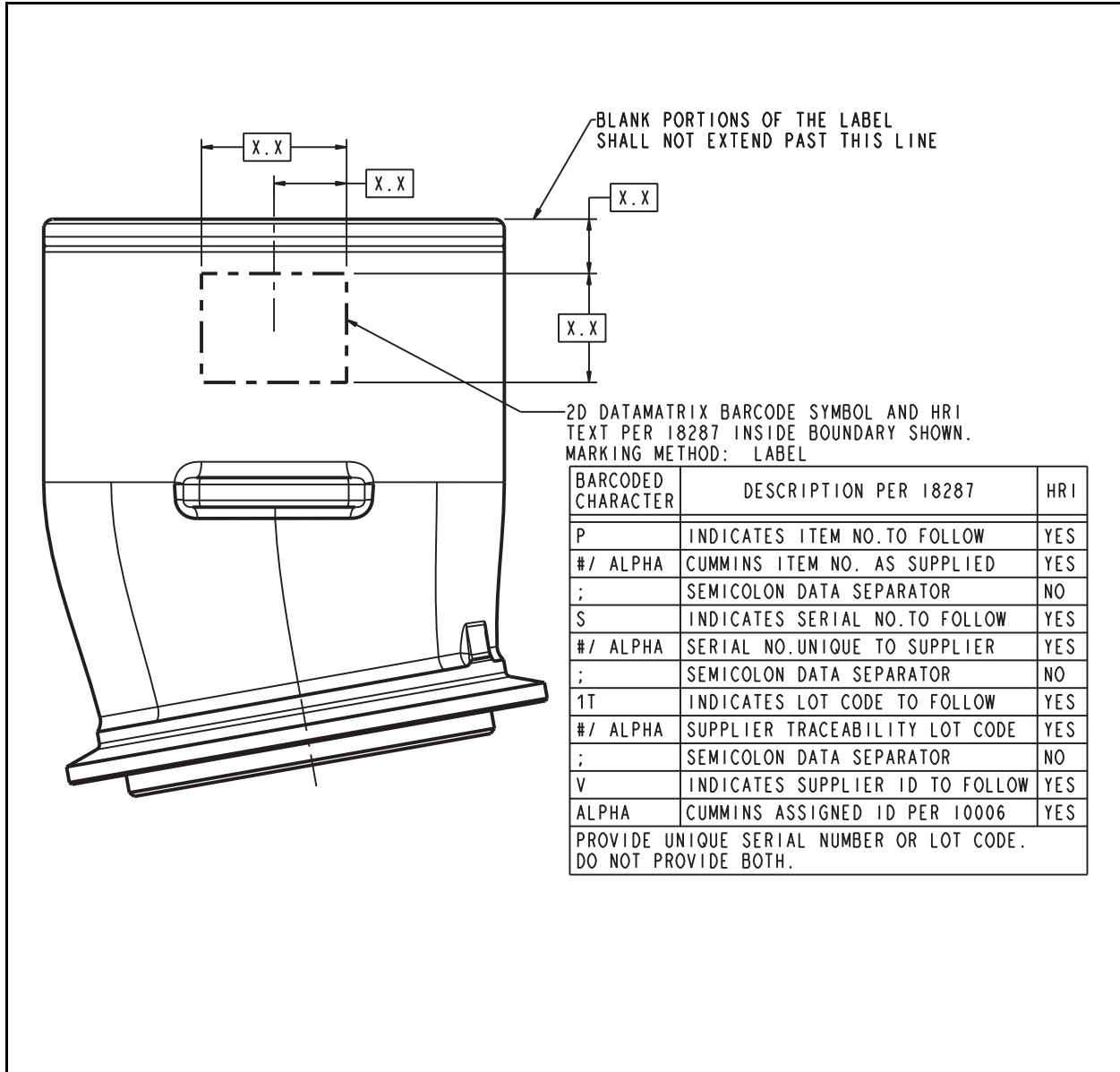

Figure 6: Barcode Content Table Showing Serial Number or Lot Code, Not Both, for Component Traceability

Current Release Number 162021-101	Std. Revision Level 011	Page 17 of 23
--------------------------------------	----------------------------	---------------

CUMMINS CONFIDENTIAL

This document (and the information shown thereon) is **CONFIDENTIAL AND PROPRIETARY** and shall not be disclosed to others in hard copy or electronic form, reproduced by any means, or used for any purpose without written consent of Cummins Inc.



Name	BARCODE LABELING & DIRECT PART MARKING	Engineering Standard Number
Identifier	CORPORATE MANUFACTURING SPECIFICATION (FEATURE)	18287

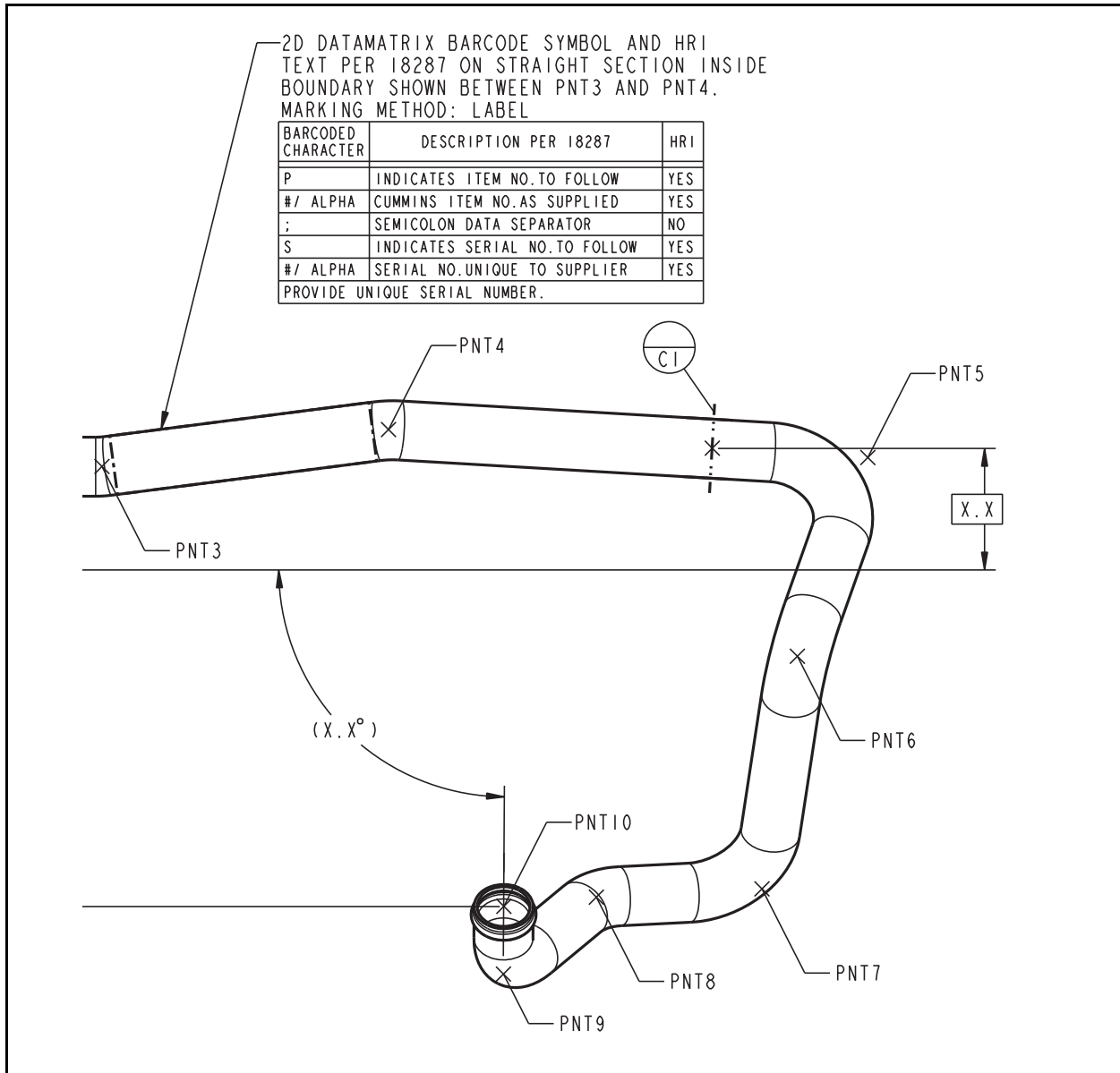

Figure 7: Barcode Content Table Shows Unique Serial Number Is Required for Component Traceability

Current Release Number 162021-101	Std. Revision Level 011		Page 18 of 23
--------------------------------------	----------------------------	--	---------------

CUMMINS CONFIDENTIAL

This document (and the information shown thereon) is **CONFIDENTIAL AND PROPRIETARY** and shall not be disclosed to others in hard copy or electronic form, reproduced by any means, or used for any purpose without written consent of Cummins Inc.



Name	BARCODE LABELING & DIRECT PART MARKING	Engineering Standard Number 18287
Identifier	CORPORATE MANUFACTURING SPECIFICATION (FEATURE)	

6. Marking Methods

6.1. Marking Methods Consideration

6.1.1. Labels: Paper

6.1.1.1. Labels provide excellent low-or no-capital-cost marking when processing permits application onto clean, dry components. They provide both the high contrast and the requisite “quiet zones” for reliable decodability. However, the component supplier shall ensure that labels satisfy generally accepted adhesion requirements (Section 9. Reference Readings on page 23, item c.). Considerations before planning a printed label program include:

- a. Ability to produce the 1D or 2D symbology(s).
- b. Ability to process on required media (size, backed media if self-adhesive).
- c. Shelf life and minimum order quantities of media, adhesive and consumables.
- d. Media/consumables compatibility with printer hardware (meets printer manufacturer specifications).
- e. Software compatibility to the printer.
- f. Communication compatibility for the printer (protocol, wiring).
- g. User’s scanner compatibility with media and consumables (e.g. infrared scanners are frequently incompatible with thermal media and dye-based inks).
- h. Print capacity-average and maximum (labels per hour).
- i. Service and support for both the printer and the media.
- j. Backup printing hardware.
- k. Can the printer produce graphics if they are required?
- l. Ability to verify legibility “in-house”.

6.1.1.2. All labels on components shall adhere to the surface with reliable decodes required throughout the reading plants assembly process until hot test or paint. Suppliers shall ensure that all labels are scratch and smudge resistant. Further, when clear overlays are required, suppliers shall ensure reliable decodes through the overlays and the overlay shall cover the entire label.

6.1.1.3. Unless specified otherwise, all labels on components shall adhere to the surface completely without having any part of the label hanging. For example, a label that goes around a tube needs to completely wrap around the tube instead of creating a “tail”. This is to avoid a situation where the tail of a label might touch a nearby heat element and melt. If it is not feasible to have a readable label without creating a tail, an exception is allowed as long as the label cannot come into contact with any heat element when in use and if it is approved by Cummins.

Current Release Number 162021-101	Std. Revision Level 011		Page 19 of 23
--------------------------------------	----------------------------	--	---------------

CUMMINS CONFIDENTIAL

This document (and the information shown thereon) is CONFIDENTIAL AND PROPRIETARY and shall not be disclosed to others in hard copy or electronic form, reproduced by any means, or used for any purpose without written consent of Cummins Inc.



Engineering Standards

Name	BARCODE LABELING & DIRECT PART MARKING	Engineering Standard Number
Identifier	CORPORATE MANUFACTURING SPECIFICATION (FEATURE)	18287

6.1.1.4. Label edges are not required to lie inside the boundary/boundaries unless otherwise specified. Blank portions of the label may lie outside the boundary/boundaries. See [Figure 1: Method One for a Label on page 12](#) and [Figure 3: Method Two for a Label on page 14](#).

6.1.2. Direct Part Marking: Laser Etching/Laser Annealing

New technologies (low wattage diode-pumped lasers) promise laser etching/annealing competitive with dot peening solutions. Laser marking is the preferred method by Cummins, and the most reliably decoded of the direct part marking methods. Some considerations include:

- a. The related controls and cooling equipment may demand a large footprint on the floor.
- b. “Normal” air cleanliness may frequently contaminate the lens, deteriorating the crispness of the laser marking. New air quality systems will be required for some laser systems.
- c. Persons working at or near high wattage lasers shall wear light filtering eye protection; hearing protection is also sometimes required. “Class 1” lasers are required to protect all persons in a 360° area around the laser. This may require complex guarding and safety interlock devices.
- d. Automation to control part orientation and location will likely add to project cost estimates.
- e. Skills to setup and maintain laser alignment and adjust etch quality may not exist within the suppliers’ organization.
- f. Laser type, power and marking time.

6.1.3. Direct Part Marking: Dot Peening

Peening methods require extra attention to mark design and lighting methods depending on the surface being marked, for reliable decodes. Typical failure causes include low contrast, especially under the brighter lighting typical of Cummins' assembly operations. Another typical failure cause is mark deterioration as the peening tool wears. Tool change frequencies shall be strictly adhered to. Dot Peening is not preferred by Cummins.

Current Release Number 162021-101	Std. Revision Level 011		Page 20 of 23
--------------------------------------	----------------------------	--	---------------

CUMMINS CONFIDENTIAL

This document (and the information shown thereon) is **CONFIDENTIAL AND PROPRIETARY** and shall not be disclosed to others in hard copy or electronic form, reproduced by any means, or used for any purpose without written consent of Cummins Inc.



Name	BARCODE LABELING & DIRECT PART MARKING	Engineering Standard Number 18287
Identifier	CORPORATE MANUFACTURING SPECIFICATION (FEATURE)	

7. Quality Control Requirements

7.1. Customer Approval

The primary requirement of barcodes is the reliable decode of information. The supplier shall supply at least one sample with 2D Barcode and HRI data to each Cummins receiving entity that will be scanning the part. Product Engineering at each receiving location shall work with Manufacturing Engineering to scan each sample and verify it can be scanned and read. Ideally, this verification should occur before the PPAP. It is best practice for the supplier to submit an electronic sample of the 2D Barcode and HRI data to Cummins before physical samples are submitted. This allows content to be validated and reduces the need for multiple physical samples. Any code not decoded will be subject to corrective action.

7.2. Suppliers' In-process Verification

Quality control for 2D Data Matrix barcodes shall be maintained and consistent. The reading quality shall be maintained from label or direct mark production, throughout supplier production, until arrival at Cummins facility. The supplier is responsible for insuring that the marking/printing process is monitored and controlled within its facility and its packaging to the receiving Cummins facility.

7.2.1. 1D Barcode Labels

Quality control requirements shall be conducted as stated in AIAG B-8 and ANSI INCITS 182 for 1D barcodes.

7.2.1.1. The supplier shall verify the quality of the barcode with the PASS/FAIL designation of Edge Determination, Minimum Reflectance, Edge Contrast Minimum, and Decode. Printed 1D barcode symbols shall meet the reflectivity and contrast requirements specified in AIAG B-8 and ANSI INCITS 182. The frequency of the audit shall be 100%, but frequency may be reduced with demonstrated process capability and agreement with the supplier and supplier Quality Engineering to verify the quality of the mark. This shall be documented in the supplier Control Plan and stored in the PPAP documentation.

7.2.1.2. The supplier shall verify the quality of the barcode and GRADED determination of Symbol Contrast, Modulation, Defects and Decodability.

Current Release Number 162021-101	Std. Revision Level 011		Page 21 of 23
--------------------------------------	----------------------------	--	---------------

CUMMINS CONFIDENTIAL

This document (and the information shown thereon) is CONFIDENTIAL AND PROPRIETARY and shall not be disclosed to others in hard copy or electronic form, reproduced by any means, or used for any purpose without written consent of Cummins Inc.



Engineering Standards

Name	BARCODE LABELING & DIRECT PART MARKING	Engineering Standard Number 18287
Identifier	CORPORATE MANUFACTURING SPECIFICATION (FEATURE)	

7.2.2. 2D Barcodes Labels and Direct Marking

7.2.2.1. The supplier shall verify 2D barcode direct part mark with use of verification equipment. The frequency of the audit shall be 100%, but frequency may be reduced with demonstrated process capability and agreement with the supplier and supplier Quality Engineering to verify the quality of the mark. This shall be documented in the supplier Control Plan and stored in the PPAP documentation.

7.2.2.2. Re-verification of 2D barcodes shall also be performed if any destructive processing (example: heat treating, sand blasting, etc.) is performed in the direct part mark area.

7.2.2.3. When part characteristics such as material dimensions, surface finish, surface texture, and reflectivity are to be altered, the change shall be approved and validated by the reading manufacturing plants. The reading plants will approve the change based upon reading capability within their facility.

7.2.2.4. Cummins has proven the ability to utilize the original bar-coding AIM verification metrics (ISO 16022) to assess barcode quality. Contrast, Print Growth, Axial Uniformity, Error Correction, and Decode can be used as pass/fail criteria for mark quality. The Print Growth parameter can be used to monitor marker performance trends and adjust setups for optimum targeting performance. Contrast parameter can be used to identify issues with lighting setup and surface color/texture variance.

7.2.2.5. At the time of this revision, industry direction on 2D Data Matrix code verification has evolved from the original AIM specification (ISO 16022) and differs for those 2D barcodes marked on labels and those for direct part marks. The industry recommends that ISO 15415 be followed for 2D barcodes on labels achieving a grade 2 or better. For direct marks on the part, it is recommended that AIM DPM-1-2006 be followed achieving a grade 2 or better, per AIAG AIM B17. The supplier is ultimately responsible to insure symbols are uniformly marked. The supplier is ultimately responsible for insuring that codes are measured for quality using the appropriate verification methods and standards.

7.3. Label Functional Requirements: Substrates

When labels are the selected application method, the supplier shall be responsible to ensure label substrates (materials) meet the expected chemical resistance (Section 9. [Reference Readings on page 23](#), item a. with addition of sulfuric acid testing), thermal resistance (Section 9. [Reference Readings on page 23](#), item b.), longevity, reflection and contrast and adhesion requirements (Section 9. [Reference Readings on page 23](#), item c.).

Current Release Number 162021-101	Std. Revision Level 011		Page 22 of 23
--------------------------------------	----------------------------	--	---------------

CUMMINS CONFIDENTIAL

This document (and the information shown thereon) is CONFIDENTIAL AND PROPRIETARY and shall not be disclosed to others in hard copy or electronic form, reproduced by any means, or used for any purpose without written consent of Cummins Inc.



Name	BARCODE LABELING & DIRECT PART MARKING	Engineering Standard Number 18287
Identifier	CORPORATE MANUFACTURING SPECIFICATION (FEATURE)	

7.4. Conditions for Corrective Action on Suppliers

Individual parts with: (1) information missing, (2) in the wrong location or orientation, or (3) unreadable codes shall be considered defective material, subject to Non Conforming Material Review (NCRM) by Supplier Quality Improvement (SQI), therefore requiring corrective action and disposition by the supplier.

8. Packaging Requirements and Labels for Packaging

Refer to the supplier portal (supplier.cummins.com) for the latest information on Cummins packaging requirements. Requirements for Global Packaging Standard of Production Parts are also found in CES 19041.

9. Reference Readings

The following references were used in the preparation of this standard.

- a. ASTM D1308, Standard Test Method for Effect of Household Chemicals on Clear and Pigmented Organic Finishes
- b. ASTM D2485 Standard Test Methods for Evaluating Coatings for High Temperature Service
- c. ASTM D3359, Measuring Adhesion by Tape Test
- d. ISO 15434, Information Technology Automatic Identification and Data Capture Techniques-Syntax for High-Capacity ADC Media
- e. ISO 16388, Information Technology-Automatic Identification and Data Capture Techniques-Code 39 Barcode Symbology Specification

Current Release Number 162021-101	Std. Revision Level 011		Page 23 of 23
--------------------------------------	----------------------------	--	---------------

CUMMINS CONFIDENTIAL

This document (and the information shown thereon) is CONFIDENTIAL AND PROPRIETARY and shall not be disclosed to others in hard copy or electronic form, reproduced by any means, or used for any purpose without written consent of Cummins Inc.